

New products to
create your success.

maykestagg
PERFORMANCE
IN PRECISION



Neuheiten / Innovations / Novità 2017

D HPC-Vollhartmetallbohrer
Speeddrill 4.0-Universal,
DIN 6537K, kurz 3xD,
4 Führungsfasen,
mit Innenkühlung

Einsatzbereich:

VHM-Hochleistungsbohrer mit Innenkühlkanälen für universelle Anwendungen. Hohe Stabilität und universelle Einsetzbarkeit durch gerade Hauptschneide. Spezialanschliff bewirkt optimalen Spanbruch, hohe Zentriergenauigkeit und geringe Schnittkräfte.

E HPC solid carbide stub drills
Speeddrill 4.0-Universal,
DIN 6537K, short series 3xD,
4 guide chamfers,
with internal coolant supply

Range of application:

Solid carbide high performance drill with internal coolant supply for universal applications. High stability as well as universal usability due to straight main cutting edge. Special point shape effects optimum chip breakage, high centering accuracy and less cutting forces.

I HPC punte elicoidali MDI
Speeddrill 4.0-Universali,
DIN 6537K, serie corta 3xD,
4 superfici di guida svasate,
con fori lubrificazione

Impiego:

Punte MDI ad alto rendimento con fori di lubrificazione interni per applicazioni universali. Alta stabilità e utilizzo universale grazie alla affilatura piatta del tagliente principale. La geometria speciale della punta garantisce un'ottima evacuazione del truciolo, una elevata accuratezza di centraggio ed una minore forza di taglio.

UNIVERSAL 3xD

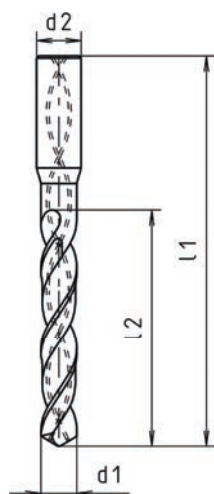
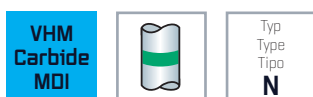
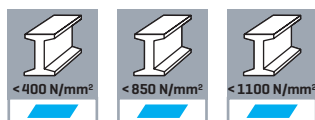

Uni

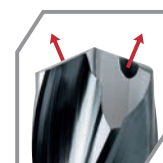

ANTRADUR

d1 _{h7} mm	d1 _{h7} inch	d2 _{h6} mm	l1 mm	l2 mm	Z	Code 6867 Art.-Nr.
3,00		6,00	62	20	2	0 6867003001 00
3,10		6,00	62	20	2	0 6867003101 00
3,17	1/8	6,00	62	20	2	0 6867003171 00
3,20		6,00	62	20	2	0 6867003201 00
3,25		6,00	62	20	2	0 6867003251 00
3,30		6,00	62	20	2	0 6867003301 00
3,38		6,00	62	20	2	0 6867003381 00
3,40		6,00	62	20	2	0 6867003401 00
3,50		6,00	62	20	2	0 6867003501 00
3,60		6,00	62	20	2	0 6867003601 00
3,65		6,00	62	20	2	0 6867003651 00

ANTRADUR

d1 _{h7} mm	d1 _{h7} inch	d2 _{h6} mm	l1 mm	l2 mm	Z	Code 6867 Art.-Nr.
3,70		6,00	62	20	2	0 6867003701 00
3,80		6,00	66	24	2	0 6867003801 00
3,90		6,00	66	24	2	0 6867003901 00
4,00		6,00	66	24	2	0 6867004001 00
4,10		6,00	66	24	2	0 6867004101 00
4,20		6,00	66	24	2	0 6867004201 00
4,30		6,00	66	24	2	0 6867004301 00
4,40		6,00	66	24	2	0 6867004401 00
4,50		6,00	66	24	2	0 6867004501 00
4,60		6,00	66	24	2	0 6867004601 00
4,65		6,00	66	24	2	0 6867004651 00

ANTRADUR
ANTRADUR

d1 _{h7} mm	d1 _{h7} inch	d2 _{h6} mm	l1 mm	l2 mm	Z	Code 6867 Art.-Nr.
4,70		6,00	66	24	2	0 6867004701 00
4,75		6,00	66	24	2	0 6867004751 00
4,76	3/16	6,00	66	28	2	0 6867004761 00
4,80		6,00	66	28	2	0 6867004801 00
4,90		6,00	66	28	2	0 6867004901 00
5,00		6,00	66	28	2	0 6867005001 00
5,10		6,00	66	28	2	0 6867005101 00
5,20		6,00	66	28	2	0 6867005201 00
5,25		6,00	66	28	2	0 6867005251 00
5,30		6,00	66	28	2	0 6867005301 00
5,40		6,00	66	28	2	0 6867005401 00
5,50		6,00	66	28	2	0 6867005501 00
5,60		6,00	66	28	2	0 6867005601 00
5,70		6,00	66	28	2	0 6867005701 00
5,75		6,00	66	28	2	0 6867005751 00
5,80		6,00	66	28	2	0 6867005801 00
5,90		6,00	66	28	2	0 6867005901 00
6,00		6,00	66	28	2	0 6867006001 00
6,10		8,00	79	34	2	0 6867006101 00
6,20		8,00	79	34	2	0 6867006201 00
6,30		8,00	79	34	2	0 6867006301 00
6,35	1/4	8,00	79	34	2	0 6867006351 00
6,40		8,00	79	34	2	0 6867006401 00
6,50		8,00	79	34	2	0 6867006501 00
6,60		8,00	79	34	2	0 6867006601 00
6,70		8,00	79	34	2	0 6867006701 00
6,80		8,00	79	34	2	0 6867006801 00
6,90		8,00	79	34	2	0 6867006901 00
7,00		8,00	79	34	2	0 6867007001 00
7,10		8,00	79	41	2	0 6867007101 00
7,20		8,00	79	41	2	0 6867007201 00
7,25		8,00	79	41	2	0 6867007251 00
7,30		8,00	79	41	2	0 6867007301 00
7,40		8,00	79	41	2	0 6867007401 00
7,45		8,00	79	41	2	0 6867007451 00
7,50		8,00	79	41	2	0 6867007501 00
7,60		8,00	79	41	2	0 6867007601 00
7,70		8,00	79	41	2	0 6867007701 00
7,75		8,00	79	41	2	0 6867007751 00
7,80		8,00	79	41	2	0 6867007801 00
7,90		8,00	79	41	2	0 6867007901 00
7,94	5/16	8,00	79	41	2	0 6867007941 00
8,00		8,00	79	41	2	0 6867008001 00
8,10		10,00	89	47	2	0 6867008101 00
8,20		10,00	89	47	2	0 6867008201 00
8,30		10,00	89	47	2	0 6867008301 00
8,40		10,00	89	47	2	0 6867008401 00
8,45		10,00	89	47	2	0 6867008451 00

d1 _{h7} mm	d1 _{h7} inch	d2 _{h6} mm	l1 mm	l2 mm	Z	Code 6867 Art.-Nr.
8,50		10,00	89	47	2	0 6867008501 00
8,60		10,00	89	47	2	0 6867008601 00
8,70		10,00	89	47	2	0 6867008701 00
8,80		10,00	89	47	2	0 6867008801 00
8,90		10,00	89	47	2	0 6867008901 00
9,00		10,00	89	47	2	0 6867009001 00
9,10		10,00	89	47	2	0 6867009101 00
9,20		10,00	89	47	2	0 6867009201 00
9,25		10,00	89	47	2	0 6867009251 00
9,30		10,00	89	47	2	0 6867009301 00
9,35		10,00	89	47	2	0 6867009351 00
9,40		10,00	89	47	2	0 6867009401 00
9,45		10,00	89	47	2	0 6867009451 00
9,50		10,00	89	47	2	0 6867009501 00
9,52	3/8	10,00	89	47	2	0 6867009521 00
9,60		10,00	89	47	2	0 6867009601 00
9,70		10,00	89	47	2	0 6867009701 00
9,75		10,00	89	47	2	0 6867009751 00
9,80		10,00	89	47	2	0 6867009801 00
9,90		10,00	89	47	2	0 6867009901 00
10,00		10,00	89	47	2	0 6867010001 00
10,10		12,00	102	55	2	0 6867010101 00
10,20		12,00	102	55	2	0 6867010201 00
10,25		12,00	102	55	2	0 6867010251 00
10,30		12,00	102	55	2	0 6867010301 00
10,40		12,00	102	55	2	0 6867010401 00
10,50		12,00	102	55	2	0 6867010501 00
10,60		12,00	102	55	2	0 6867010601 00
10,70		12,00	102	55	2	0 6867010701 00
10,75		12,00	102	55	2	0 6867010751 00
10,80		12,00	102	55	2	0 6867010801 00
10,90		12,00	102	55	2	0 6867010901 00
11,00		12,00	102	55	2	0 6867011001 00
11,10		12,00	102	55	2	0 6867011101 00
11,11	7/16	12,00	102	55	2	0 6867011111 00
11,20		12,00	102	55	2	0 6867011201 00
11,25		12,00	102	55	2	0 6867011251 00
11,30		12,00	102	55	2	0 6867011301 00
11,35		12,00	102	55	2	0 6867011351 00
11,40		12,00	102	55	2	0 6867011401 00
11,45		12,00	102	55	2	0 6867011451 00
11,50		12,00	102	55	2	0 6867011501 00
11,60		12,00	102	55	2	0 6867011601 00
11,70		12,00	102	55	2	0 6867011701 00
11,75		12,00	102	55	2	0 6867011751 00
11,80		12,00	102	55	2	0 6867011801 00
11,90		12,00	102	55	2	0 6867011901 00
12,00		12,00	102	55	2	0 6867012001 00

D HPC-Vollhartmetallbohrer
Speeddrill 4.0-Universal,
DIN 6537L, lang 5xD,
4 Führungsfasen,
mit Innenkühlung

Einsatzbereich:

VHM-Hochleistungsbohrer mit Innenkühlkanälen für universelle Anwendungen. Hohe Stabilität und universelle Einsetzbarkeit durch gerade Hauptschneide. Spezialanschliff bewirkt optimalen Spanbruch, hohe Zentriergenauigkeit und geringe Schnittkräfte.

E HPC solid carbide stub drills
Speeddrill 4.0-Universal,
DIN 6537L, long series 5xD,
4 guide chamfers,
with internal coolant supply

Range of application:

Solid carbide high performance drill with internal coolant supply for universal applications. High stability as well as universal usability due to straight main cutting edge. Special point shape effects optimum chip breakage, high centering accuracy and less cutting forces.

I HPC punte elicoidali MDI
Speeddrill 4.0-Universali,
DIN 6537L, serie lunga 5xD,
4 superfici di guida svasate,
con fori lubrificazione

Impiego:

Punte MDI ad alto rendimento con fori di lubrificazione interni per applicazioni universali. Alta stabilità e utilizzo universale grazie alla particolare affilatura dei taglienti principali. La geometria speciale della punta garantisce un'ottima rottura del truciolo, una elevata accuratezza di centraggio ed una minore forza di taglio.

UNIVERSAL 5xD

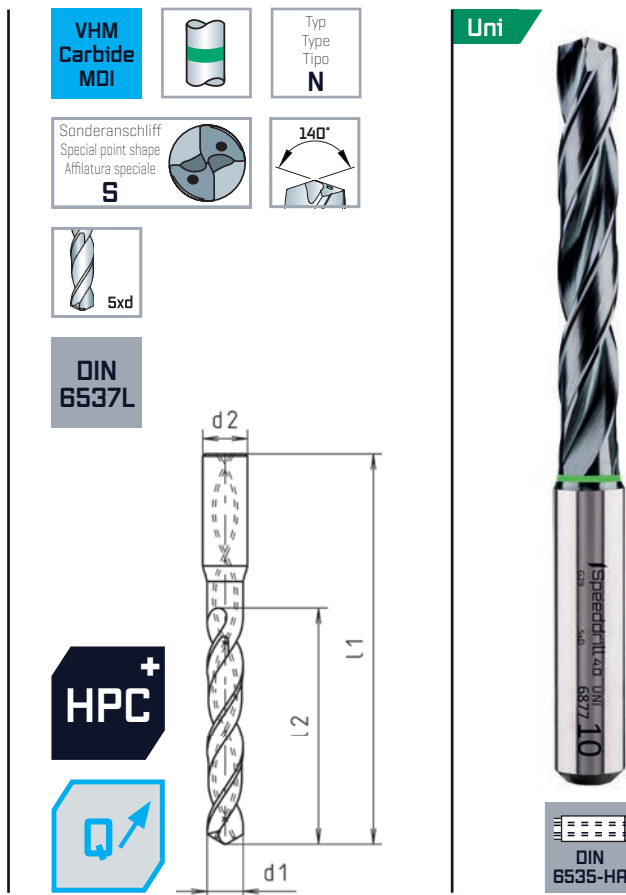
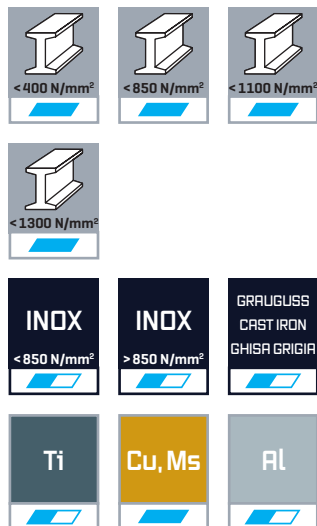

ANTRADUR

d1 _{h7} mm	d1 _{h7} inch	d2 _{h6} mm	l1 mm	l2 mm	Z	Code 6877 Art.-Nr.
3,00		6,00	66	28	2	0 6877003001 00
3,10		6,00	66	28	2	0 6877003101 00
3,17	1/8	6,00	66	28	2	0 6877003171 00
3,20		6,00	66	28	2	0 6877003201 00
3,25		6,00	66	28	2	0 6877003251 00
3,30		6,00	66	28	2	0 6877003301 00
3,38		6,00	66	28	2	0 6877003381 00
3,40		6,00	66	28	2	0 6877003401 00
3,50		6,00	66	28	2	0 6877003501 00
3,60		6,00	66	28	2	0 6877003601 00
3,65		6,00	66	28	2	0 6877003651 00

ANTRADUR

d1 _{h7} mm	d1 _{h7} inch	d2 _{h6} mm	l1 mm	l2 mm	Z	Code 6877 Art.-Nr.
3,70		6,00	66	28	2	0 6877003701 00
3,80		6,00	74	36	2	0 6877003801 00
3,90		6,00	74	36	2	0 6877003901 00
4,00		6,00	74	36	2	0 6877004001 00
4,10		6,00	74	36	2	0 6877004101 00
4,20		6,00	74	36	2	0 6877004201 00
4,30		6,00	74	36	2	0 6877004301 00
4,40		6,00	74	36	2	0 6877004401 00
4,50		6,00	74	36	2	0 6877004501 00
4,60		6,00	74	36	2	0 6877004601 00
4,65		6,00	74	36	2	0 6877004651 00

ANTRADUR

d1 _{h7} mm	d1 _{h7} inch	d2 _{h6} mm	l1 mm	l2 mm	Z	Code 6877 Art.-Nr.
4,70		6,00	74	36	2	0 6877004701 00
4,75		6,00	74	36	2	0 6877004751 00
4,76	3/16	6,00	82	44	2	0 6877004761 00
4,80		6,00	82	44	2	0 6877004801 00
4,90		6,00	82	44	2	0 6877004901 00
5,00		6,00	82	44	2	0 6877005001 00
5,10		6,00	82	44	2	0 6877005101 00
5,20		6,00	82	44	2	0 6877005201 00
5,25		6,00	82	44	2	0 6877005251 00
5,30		6,00	82	44	2	0 6877005301 00
5,40		6,00	82	44	2	0 6877005401 00
5,50		6,00	82	44	2	0 6877005501 00
5,60		6,00	82	44	2	0 6877005601 00
5,70		6,00	82	44	2	0 6877005701 00
5,75		6,00	82	44	2	0 6877005751 00
5,80		6,00	82	44	2	0 6877005801 00
5,90		6,00	82	44	2	0 6877005901 00
6,00		6,00	82	44	2	0 6877006001 00
6,10		8,00	91	53	2	0 6877006101 00
6,20		8,00	91	53	2	0 6877006201 00
6,30		8,00	91	53	2	0 6877006301 00
6,35	1/4	8,00	91	53	2	0 6877006351 00
6,40		8,00	91	53	2	0 6877006401 00
6,50		8,00	91	53	2	0 6877006501 00
6,60		8,00	91	53	2	0 6877006601 00
6,70		8,00	91	53	2	0 6877006701 00
6,80		8,00	91	53	2	0 6877006801 00
6,90		8,00	91	53	2	0 6877006901 00
7,00		8,00	91	53	2	0 6877007001 00
7,10		8,00	91	53	2	0 6877007101 00
7,20		8,00	91	53	2	0 6877007201 00
7,25		8,00	91	53	2	0 6877007251 00
7,30		8,00	91	53	2	0 6877007301 00
7,40		8,00	91	53	2	0 6877007401 00
7,45		8,00	91	53	2	0 6877007451 00
7,50		8,00	91	53	2	0 6877007501 00
7,60		8,00	91	53	2	0 6877007601 00
7,70		8,00	91	53	2	0 6877007701 00
7,75		8,00	91	53	2	0 6877007751 00
7,80		8,00	91	53	2	0 6877007801 00
7,90		8,00	91	53	2	0 6877007901 00
7,94	5/16	8,00	91	53	2	0 6877007941 00
8,00		8,00	91	53	2	0 6877008001 00
8,10		10,00	103	61	2	0 6877008101 00
8,20		10,00	103	61	2	0 6877008201 00
8,30		10,00	103	61	2	0 6877008301 00
8,40		10,00	103	61	2	0 6877008401 00
8,45		10,00	103	61	2	0 6877008451 00

ANTRADUR

d1 _{h7} mm	d1 _{h7} inch	d2 _{h6} mm	l1 mm	l2 mm	Z	Code 6877 Art.-Nr.
8,50		10,00	103	61	2	0 6877008501 00
8,60		10,00	103	61	2	0 6877008601 00
8,70		10,00	103	61	2	0 6877008701 00
8,80		10,00	103	61	2	0 6877008801 00
8,90		10,00	103	61	2	0 6877008901 00
9,00		10,00	103	61	2	0 6877009001 00
9,10		10,00	103	61	2	0 6877009101 00
9,20		10,00	103	61	2	0 6877009201 00
9,25		10,00	103	61	2	0 6877009251 00
9,30		10,00	103	61	2	0 6877009301 00
9,35		10,00	103	61	2	0 6877009351 00
9,40		10,00	103	61	2	0 6877009401 00
9,45		10,00	103	61	2	0 6877009451 00
9,50		10,00	103	61	2	0 6877009501 00
9,52	3/8	10,00	103	61	2	0 6877009521 00
9,60		10,00	103	61	2	0 6877009601 00
9,70		10,00	103	61	2	0 6877009701 00
9,75		10,00	103	61	2	0 6877009751 00
9,80		10,00	103	61	2	0 6877009801 00
9,90		10,00	103	61	2	0 6877009901 00
10,00		10,00	103	61	2	0 6877010001 00
10,10		12,00	118	71	2	0 6877010101 00
10,20		12,00	118	71	2	0 6877010201 00
10,25		12,00	118	71	2	0 6877010251 00
10,30		12,00	118	71	2	0 6877010301 00
10,40		12,00	118	71	2	0 6877010401 00
10,50		12,00	118	71	2	0 6877010501 00
10,60		12,00	118	71	2	0 6877010601 00
10,70		12,00	118	71	2	0 6877010701 00
10,75		12,00	118	71	2	0 6877010751 00
10,80		12,00	118	71	2	0 6877010801 00
10,90		12,00	118	71	2	0 6877010901 00
11,00		12,00	118	71	2	0 6877011001 00
11,10		12,00	118	71	2	0 6877011101 00
11,11	7/16	12,00	118	71	2	0 6877011111 00
11,20		12,00	118	71	2	0 6877011201 00
11,25		12,00	118	71	2	0 6877011251 00
11,30		12,00	118	71	2	0 6877011301 00
11,35		12,00	118	71	2	0 6877011351 00
11,40		12,00	118	71	2	0 6877011401 00
11,45		12,00	118	71	2	0 6877011451 00
11,50		12,00	118	71	2	0 6877011501 00
11,60		12,00	118	71	2	0 6877011601 00
11,70		12,00	118	71	2	0 6877011701 00
11,75		12,00	118	71	2	0 6877011751 00
11,80		12,00	118	71	2	0 6877011801 00
11,90		12,00	118	71	2	0 6877011901 00
12,00		12,00	118	71	2	0 6877012001 00

D VHM-Mehrzahl Schlichtfräser Speedtwister-Universal, extra lang 5xD

Einsatzbereich:

VHM-Hochleistungsschlichtfräser für universellen Einsatz in Baustähle, Werkzeugstähle, Vergütungsstähle, aber auch rostfreien Stählen und Titanlegierungen bis 50 HRC.

Durch einen sehr starken Fräserkern und modifiziertem Stirnschliff mit kleiner Eckenschutzfase werden sehr hohe Zerspanungsleistungen mit exzellenter Oberflächengüte erzielt.

E Solid carbide multi flute finishing end mill Speedtwister-Universal, extra long series 5xD

Range of application:

High performance carbide finishing end mill for universal applications into structural steels, tool steels, treatable steels but also for stainless steels and titanium alloys up to 50 HRC.

Due to a very strong core and an improved face grinding with small cutting edge chamfer, very high cutting performances with excellent surface quality will be achieved.

I Fresa in metallo duro multitagliente per finitura Speedtwister-Universale, extra serie lunga 5xD

Impiego:

Fresa a finire in Metallo Duro ad alto rendimento per applicazioni universali idonea per acciai strutturali, acciai da utensili, acciai da tempra ma anche per acciai inossidabili e leghe di titanio fino a 50 HRC. Grazie al nocciolo rinforzato e ad una migliorata superficie rettificata con piccoli smussi di protezione e' possibile raggiungere rendimenti di taglio molto elevati ed eccellenti qualità di finitura.

UNIVERSAL 5xD

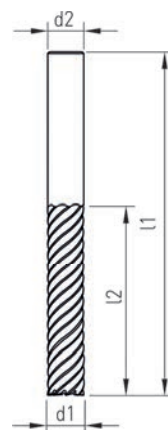
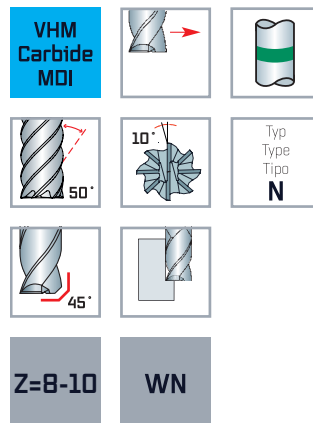

Uni



ALUNIT-S®

d1 _{e8} mm	d2 _{h6} mm	l1 mm	l2 mm		Z	Code 6199 Art.-Nr.
6	6	70	32	0,05	8	0 6199006001 00
8	8	80	42	0,05	8	0 6199008001 00
10	10	99	52	0,05	8	0 6199010001 00
12	12	115	62	0,05	8	0 6199012001 00
16	16	140	82	0,10	10	0 6199016001 00

**D STC-Schaftfräser
Speedtwister-Inox,**
extra lang XL, Fünfschneider,
ungleiche Drallsteigung, **5xD,**
mit Innenkühlung

Einsatzbereich:
Trochoidaler Hochleistungsfräser für austenitische rostfreie Stähle. Für statische und dynamische Bearbeitungen. Sehr hohe Laufruhe und perfekte Spankontrolle durch modernste Werkzeuggeometrien setzt neue Maßstäbe in der Zerspanungsleistung.

**E STC end mill
Speedtwister-Inox,**
extra long series XL, five flutes,
different spiral angles, **5xD,**
with internal coolant supply

Range of application:
Trochoidal high performance carbide end mill for austenitic stainless steels. For static and dynamic strategies. Very smooth operation and perfect chip control through modern tool geometry sets new standards in chip removal.

**I Fresa frontale STC
Speedtwister-Inox,**
serie extra lunga XL, 5 taglienti,
angolo elica disuguale, **5xD,**
con fori lubrificazione

Impiego:
Fresa trocoidale ad alto rendimento per la lavorazione di acciai austenitici inossidabili. Idonea per fresatura statiche e dinamiche. Elevata silenziosità e un perfetto controllo del truciolo dalla più moderna geometria dell'utensile stabilisce nuove standard nell'trasporto truciolo.

INOX 5xD

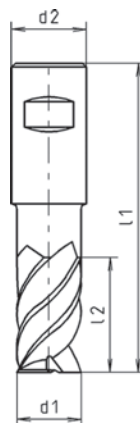
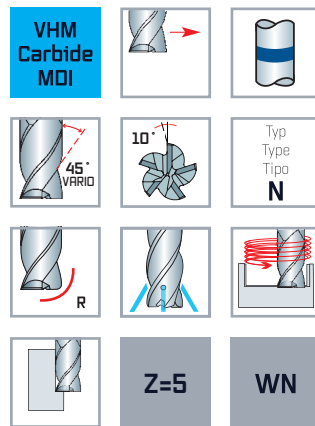

Inox



ULTRADUR

d1 _{fg} mm	d2 _{h6} mm	l1 mm	l2 mm	 R	Z	Code 6198 Art.-Nr.
6	6	70	32	0,5	5	0 6198006001 00
8	8	80	42	0,5	5	0 6198008001 00
10	10	99	52	0,5	5	0 6198010001 00
12	12	115	62	0,5	5	0 6198012001 00
16	16	140	82	0,5	5	0 6198016001 00

D HSS Cobalt Kegelsenker ungleiche Teilung
DIN 335 C, 90°

Einsatzbereich:

Für alle E- und NE-Metalle, Kunststoffe hart und weich. Universell einsetzbares Entgrat- und Senkwerkzeug für Bohrungen aller Art. Sehr gute Schneideigenschaften durch ungleichgeteilte Schneiden.



E HSS Cobalt countersinks different partition
DIN 335 C, 90°

Range of application:

For ferrous and non-ferrous metals, synthetic materials soft and hard. Universal deburring and sink tool for all kind of borings. Excellent cutting features guarantee a smooth surface by unequally divided cutting edges.

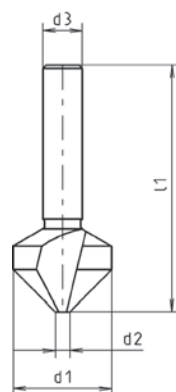
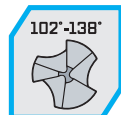
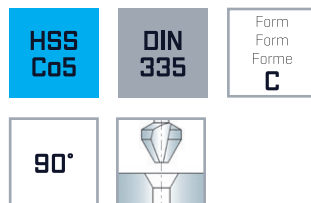

I Svasatori HSS Cobalt disuguale tagliente
DIN 335 C, 90°

Impiego:

Adatti per tutti i materiali ferrosi, non ferrosi, plastiche dure e dolci, per sbavature e svasature di tutti i tipi di fori. Perfette proprietà di taglio, a causa di disuguale tagliente.

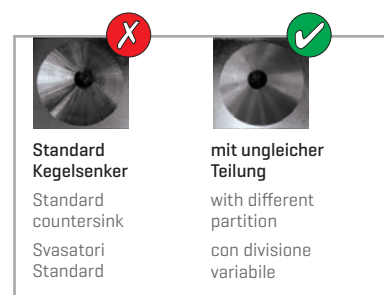

ALUNIT®

d1 mm	d2 mm	d3 _{h9} mm	l1 mm	Z	Code 2390 Art.-Nr.	Code 2397 Art.-Nr.
6,30	M3	1,50	5,00	45	0 2390006301 00	0 2397006301 00
8,30	M4	2,00	6,00	50	0 2390008301 00	0 2397008301 00
10,40	M5	2,50	6,00	50	0 2390010401 00	0 2397010401 00
12,40	M6	2,80	8,00	56	0 2390012401 00	0 2397012401 00
16,50	M8	3,20	10,00	60	0 2390016501 00	0 2397016501 00
20,50	M10	3,50	10,00	63	0 2390020501 00	0 2397020501 00
25,00	M12	3,80	10,00	67	0 2390025001 00	0 2397025001 00
31,00		4,20	12,00	71	0 2390031001 00	0 2397031001 00

**D HSS Cobalt Kegelsenker
3-Flächenschaft,
ungleiche Teilung,
DIN 335 C, 90°**

Einsatzbereich:

Für alle E- und NE-Metalle, Kunststoffe hart und weich. Universell einsetzbares Entgrat- und Senkwerkzeug für Bohrungen aller Art. Sehr gute Schneideigenschaften durch ungleichgeteilte Schneiden.



**E HSS Cobalt countersinks
3-surface shank,
different partition,
DIN 335 C, 90°**

Range of application:

For ferrous and non-ferrous metals, synthetic materials soft and hard. Universal deburring and sink tool for all kind of borings. Excellent cutting features guarantee a smooth surface by unequally divided cutting edges.

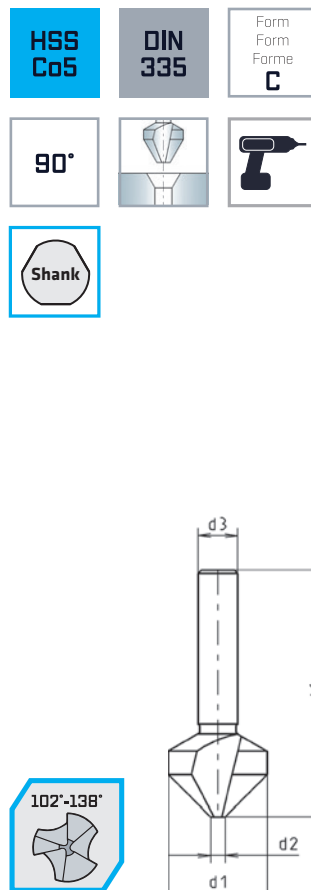

**I Svasatori HSS Cobalt
Codolo a 3 superfici
disuguale tagliente
DIN 335 C, 90°**

Impiego:

Adatti per tutti i materiali ferrosi, non ferrosi, plastiche dure e dolci, per sbavature e svasature di tutti i tipi di fori. Perfette proprietà di taglio, a causa di disuguale tagliente.

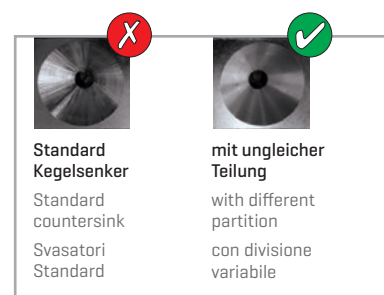

ALUNIT®

d1 mm		d2 mm	d3 _{h9} mm	l1 mm	Z	Code 2380 Art.-Nr.	Code 2387 Art.-Nr.
6,30	M3	1,50	5,00	45	3	0 2380006301 00	0 2387006301 00
8,30	M4	2,00	6,00	50	3	0 2380008301 00	0 2387008301 00
10,40	M5	2,50	6,00	50	3	0 2380010401 00	0 2387010401 00
12,40	M6	2,80	8,00	56	3	0 2380012401 00	0 2387012401 00
16,50	M8	3,20	10,00	60	3	0 2380016501 00	0 2387016501 00
20,50	M10	3,50	10,00	63	3	0 2380020501 00	0 2387020501 00
25,00	M12	3,80	10,00	67	3	0 2380025001 00	0 2387025001 00
31,00		4,20	12,00	71	3	0 2380031001 00	0 2387031001 00

Hartmetall-Frässtifte

Einsatzbereich:

Herausragende Fräsleistung bei Edelstahl sowie ferritischen, austenitischen und martensitischen Materialien.

Tungsten carbide rotary burrs,

Range of application:

Outstanding milling performance in stainless steel as well as ferritic, austenitic and martensitic materials.

Lime rotative in metallo duro

Campo applicazione:

Elevato rendimento di fresatura nell'acciaio inossidabile e nei materiali ferritici, austenitici e martensiteici.



D Spitzbogen

E arc pointed nose

I a lancia

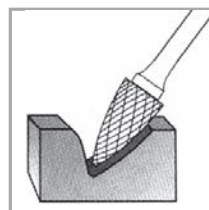

DIN
SPG

ISO
G



d1 mm	d2 mm	l1 mm	l2 mm	Code 7800 Art.-Nr.
6,00	6	50	16	0 7800061061 00
8,00	6	65	20	0 7800061081 00
10,00	6	65	20	0 7800061101 00
12,00	6	70	25	0 7800061121 00

D Zylinder, ohne Stirnverzahnung

E cylindrical, without front cut

I cilindriche, senza taglio in testa

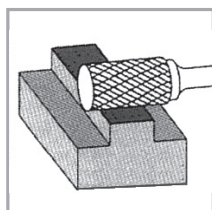

DIN
ZYA

ISO
A



d1 mm	d2 mm	l1 mm	l2 mm	Code 7770 Art.-Nr.
6,00	6	50	16	0 7770061061 00
8,00	6	65	20	0 7770061081 00
10,00	6	65	20	0 7770061101 00
12,00	6	70	25	0 7770061121 00

D Rundbogen

E arc round nose

I a lancia raggata

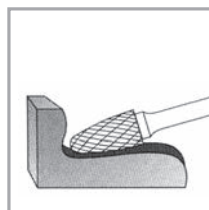

DIN
RBF

ISO
F



d1 mm	d2 mm	l1 mm	l2 mm	Code 7880 Art.-Nr.
6,00	6	50	18	0 7880061061 00
8,00	6	63	18	0 7880061081 00
10,00	6	65	20	0 7880061101 00
12,00	6	70	25	0 7880061121 00

D Walzenrund

E ball nose

I cilindriche sferica

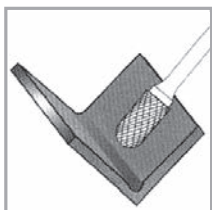

DIN
WRC

ISO
C



d1 mm	d2 mm	l1 mm	l2 mm	Code 7790 Art.-Nr.
6,00	6	50	16	0 7790061061 00
8,00	6	65	20	0 7790061081 00
10,00	6	65	20	0 7790061101 00
12,00	6	70	25	0 7790061121 00

D Rundkegel

E conical round nose

I conica raggata

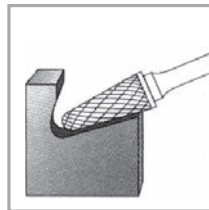

DIN
KEL

ISO
L



d1 mm	d2 mm	l1 mm	l2 mm	Code 7890 Art.-Nr.
8,00	6	65	20	0 7890061081 00
10,00	6	65	20	0 7890061101 00
12,00	6	70	25	0 7890061121 00

SPECIAL STEEL

Hartmetall-Frässtifte

Einsatzbereich:
Speziell entwickelte Geometrie für Stahl- und Gusseisenanwendungen.
Hervorragende Zerspanungsleistung und hoher Materialabtrag.

Tungsten carbide rotary burrs,

Range of application:
Special designed geometry for steel and cast iron applications.
Excellent cutting performance and high chip removal.

Lime rotative in metallo duro

Campo applicazione:
Geometria speciale per applicazioni in acciaio e ghisa. Eccellente rendimento di taglio e elevata rimozione del truciolo.



- D** Spitzbogen
- E** arc pointed nose
- I** a lancia

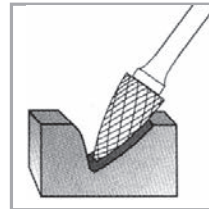

DIN
SPG

ISO
G



d1 mm	d2 mm	l1 mm	l2 mm	Code 7809 Art.-Nr.
6,00	6	50	16	0 7809061061 00
8,00	6	65	20	0 7809061081 00
10,00	6	65	20	0 7809061101 00
12,00	6	70	25	0 7809061121 00

- D** Zylinder, mit Stirnverzahnung
- E** cylindrical, with front cut
- I** cilindrica, taglio in testa

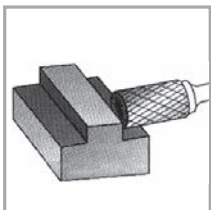

DIN
ZYA-S



ISO
A-S



d1 mm	d2 mm	l1 mm	l2 mm	Code 7789 Art.-Nr.
6,00	6	50	16	0 7789061061 00
8,00	6	65	20	0 7789061081 00
10,00	6	65	20	0 7789061101 00
12,00	6	70	25	0 7789061121 00

- D** Rundbogen
- E** arc round nose
- I** a lancia raggiata

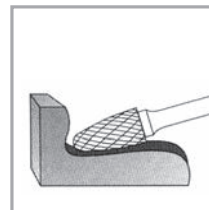

DIN
RBF

ISO
F



d1 mm	d2 mm	l1 mm	l2 mm	Code 7889 Art.-Nr.
6,00	6	50	18	0 7889061061 00
8,00	6	63	18	0 7889061081 00
10,00	6	65	20	0 7889061101 00
12,00	6	70	25	0 7889061121 00

- D** Walzenrund
- E** ball nose
- I** cilindrica sferica

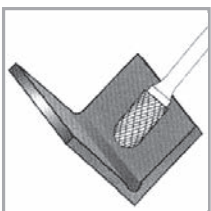

DIN
WRC

ISO
C



d1 mm	d2 mm	l1 mm	l2 mm	Code 7799 Art.-Nr.
6,00	6	50	16	0 7799061061 00
8,00	6	65	20	0 7799061081 00
10,00	6	65	20	0 7799061101 00
12,00	6	70	25	0 7799061121 00

- D** Rundkegel
- E** conical round nose
- I** conica raggiata

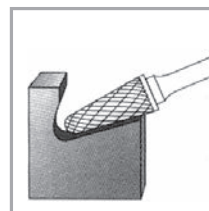

DIN
KEL

ISO
L



d1 mm	d2 mm	l1 mm	l2 mm	Code 7899 Art.-Nr.
10,00	6	65	20	0 7899061101 00
12,00	6	70	25	0 7899061121 00

Überreicht durch | With the compliments of | Utensileria:

ÖSTERREICH

ALPEN-MAYKESTAG GmbH

Urstein Nord 67 | A-5412 Puch / Salzburg
Tel: +43 [0] 662 449 01-0
Fax: +43 [0] 662 449 01-110
Fax Export: +43 [0] 662 449 01-130
verkauf@a-mk.com
export@a-mk.com

DEUTSCHLAND

ALPEN-MAYKESTAG GmbH

Hansaallee 201 | D-40549 Düsseldorf
Tel: +49 [0] 211 53 75 50-0
Fax: +49 [0] 211 59 35 73
verkauf@a-mk.com

ITALIA

ALPEN-MAYKESTAG s.r.l.

Via Volontari Del Sangue 54 | I-20093 Cologno Monzese (MI)
Tel: +39 [02] 48 84 30 38
Fax: +39 [02] 45 70 14 19
info@a-mk.it

ČESKÁ REPUBLIKA

ALPEN-MAYKESTAG s.r.o.

U Koruny 414 | CZ-50002 Hradec Králové
Tel. +420 495 58 23 22
Fax +420 495 58 23 25
info@a-mk.cz

MAGYARORSZÁG

ALPEN-MAYKESTAG Kft.

Gyár utca 5 | H-8500 Pápa
Tel. +36 [0] 89 51 15 15
Fax +36 [0] 89 51 15 16
info@a-mk.hu